

SENTRY Modular General Purpose Regulators

R10M, R11M Models Port Sizes: 1/8, 1/4; Tube Fittings



Model Shown: R10M-2G

- ◆ Modular assembly and mounting.
- ◆ Threaded ports or quick-connect fittings for tubing up to 10 mm in diameter.
- ◆ Piston-type design (R10M models) or diaphragm-type (R11M models).
- ◆ Self-relieving; non-relieving optional.
- ◆ Pressure gauge.
- ◆ NPTF port threads; optional BSPP threads or fittings for tubing up to 10 mm.

SPECIFICATIONS

Ambient/Media Temperature:
40° to 125°F (4° to 52°C).

Body: Acetal.

Dome and Knob: Acetal

Fluid Media: Compressed air.

Inlet Pressure: 150 psig (10 bar) maximum.

Outlet Pressure: Adjustable up to 100 psig (7 bar).

Pressure Gauge: 0 to 160 psig (11 bar); 1/8 gauge ports front and rear.

Panel Mounting: 1-3/16 inch (30 mm) hole required.

Seals: Nitrile.

FLOW CHART

Inlet Pressure: 100 psig (7 bar)

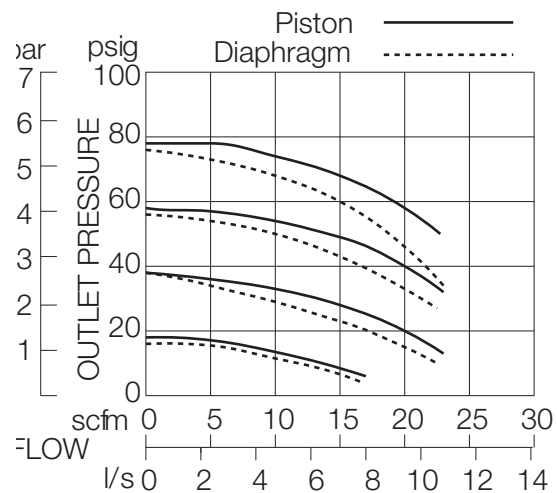

DIMENSIONS inches (mm)

Ports	A	B	C	Depth †	Weight † lb (kg)
No Port	1.7 (43)	2.6 (67)	0.5 (13)	1.8 (45)	0.21 (0.09)
1/8, 1/4	3.0 (76)	2.6 (67)	0.5 (13)	1.8 (45)	0.43 (0.19)
Models below have quick-connect fittings for tubing.					
1/4	3.4 (86)	2.6 (67)	0.5 (13)	1.8 (45)	0.21 (0.09)
3/8	3.9 (99)	2.6 (67)	0.5 (13)	1.8 (45)	0.21 (0.09)
4 mm	3.4 (86)	2.6 (67)	0.5 (13)	1.8 (45)	0.41 (0.18)
6 mm	3.4 (86)	2.6 (67)	0.5 (13)	1.8 (45)	0.41 (0.18)
8 mm	3.4 (86)	2.6 (67)	0.5 (13)	1.8 (45)	0.41 (0.18)
10 mm	3.9 (99)	2.6 (67)	0.5 (13)	1.8 (45)	0.41 (0.18)

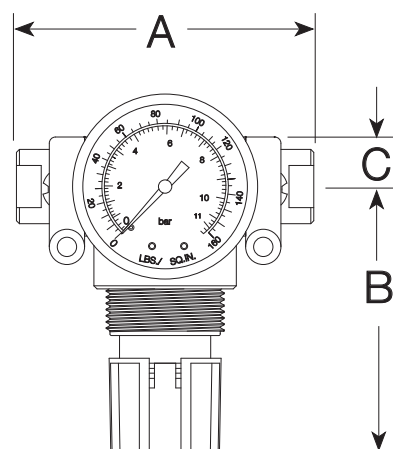

† Less gauge.

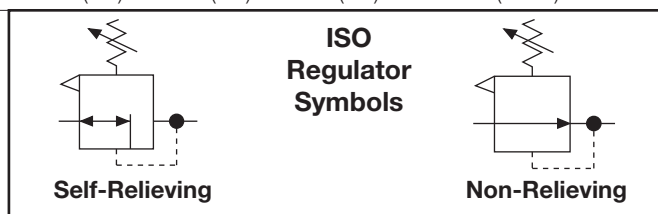

ORDERING INFORMATION

Change the letters in the sample model number below to specify the regulator you want.

R10M P - 2 X Y G W

REGULATOR TYPE

Piston typeR10M
Diaphragm type.....R11M

MOUNTING HOLE LOCATION

Bottom mount (Standard) Leave Blank
Top mount P

INLET PORT SIZE

No Inlet and Outlet ports.... Leave blank

Threaded:

1/8 NPTF -1
1/4 NPTF -2

Fittings for Tubing:

1/4 -04
3/8 -06
4 mm -M4
6 mm -M6
8 mm -M8
10 mm -M10

OUTLET PORT SIZE

Same as inlet port Leave Blank

Threaded:

1/8 NPTF 1
1/4 NPTF 2

Fittings for Tubing:

1/4 04
3/8 06
4 mm M4
6 mm M6
8 mm M8
10 mm M10

MOUNTING BRACKETS

See page 346.

PORT TYPE

As specified in **INLET PORT**... Leave Blank
BSPB threads on both ports W

OPTIONS (More than one option can be chosen. Add in alphabetical order)

Delete gauge Leave Blank
0-160 PSI Gauge G
Plastic mounting nut P
Metal mounting nut..... PN
Hex plastic mounting nut PE

OPTIONS (More than one option can be chosen. Add in alphabetical order)

None Leave Blank
Non-relieving A
Springs: (0-100 psig standard)
For optimum performance operating pressure should fall approximately in the middle of the spring range.
0-125 psig (0-8.6 bar) H
0-50 psig (0-3.4 bar) L
0-8 psig (0-0.6 bar) L8
0-15 psig (0-1 bar) L15
0-30 psig (0-2.1 bar) L30
Tamper-resistant spinning MV(*)
knob (psig preset)
Viton seals..... V

*Insert maximum limited pressure.