

High-Flow VANGUARD Coalescing Filters

BFGD201 Models Port Sizes: 1-1/4, 1-1/2



Model Shown: BFGD201-10

SPECIFICATIONS

Ambient/Media Temperature:

Manual & auto drains: 40° to 175°F (4° to 79°C).

Float drains: 40° to 150°F (4° to 66°C).

Body: Aluminum.

Bowl: 35-Ounce (1050-ml) capacity aluminum bowl.
Optional 62-ounce (1860-ml) extended aluminum bowl has higher capacity filter element for increased air flow.

Bowl Drain:

Internal automatic drain; optional manual drain and internal float drain.

Bowl Ring: Aluminum.

Differential Pressure Gauge: Large 106-35.

Filter Element: 0.3- μ m-rated borosilicate-glass-fiber coalescing element; optional 0.01- μ m-rated element.

Fluid Media: Compressed air.

Inlet Pressure:

Minimum: 15 psig (1 bar) with automatic drain, 30 psig (2 bar) with internal float drain.

Maximum: 200 psig (14 bar)

Seals: Nitrile.

- ◆ Inline mounting.
- ◆ 0.3- μ m-rated coalescing filter element; optional 0.01- μ m element.
- ◆ Differential pressure gauge.
- ◆ Aluminum bowl. Optional extended bowl with higher flow element.
- ◆ Internal automatic drain; optional manual drain and internal float drain.
- ◆ NPTF port threads; optional BSPP threads.

APPLICATION NOTE: A general purpose filter must be installed ahead of a coalescing filter to ensure good performance and to extend the life of the coalescing element.

FLOW CHARTS

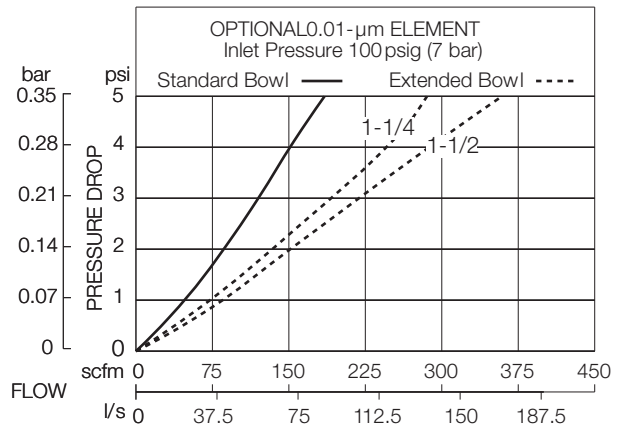
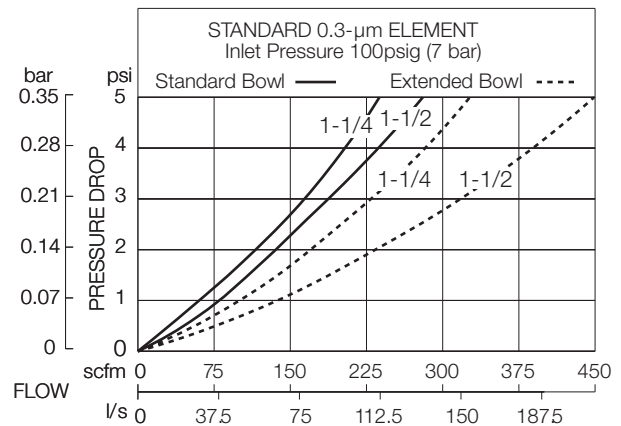

DIMENSIONS inches (mm)

Bowl	A	B	C	Depth	Weight lb (kg)
Standard	5.5 (140)	10.6 (270)	3.7 (94)	4.2 (106)	4.31 (1.94)
Extended	5.5 (140)	16.2 (412)	3.7 (94)	4.2 (106)	5.00 (2.27)

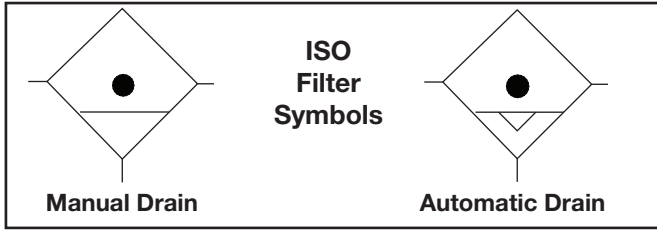

REPLACEMENT FILTER ELEMENT KITS

Element Type	Kit Number
0.3 µm Standard bowl (Std element)	A114-112
0.3 µm Extended bowl	A114-113
Models with E8 option:	
0.01 µm Standard bowl	A114-112E8
0.01 µm Extended bowl	A114-113E8

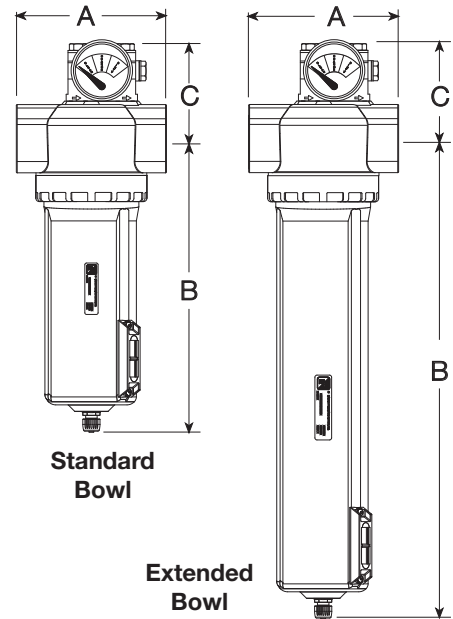

ORDERING INFORMATION

Change the letters in the sample model number below to specify the filter you want.

BFC D 201 - 10 Y W

BOWL DRAIN

Internal automatic drain BFC D
 Manual Drain BFC
 Internal Float drain (*brass stem*) BFC6A

BOWL SIZE & DIFFERENTIAL

PRESSURE GAUGE

Standard bowl, no gauge..... 201
 Also add 'NG' under **Option Menu**.
 Standard bowl & large gauge 201
 Standard bowl & small gauge 201S
 Standard bowl & large gauge with 201E
 normally open reed switch.
 Standard bowl & large gauge with 201E2
 normally closed reed switch.
 Extended bowl, no gauge..... 201H
 Also add 'NG' under **Option Menu**.
 Extended bowl & large gauge 201H
 Extended bowl & small gauge 201HS
 Extended bowl & large gauge with 201HE
 normally **open** reed switch.
 Extended Bowl & large gauge with 201HE2
 normally **closed** reed switch.

PORT TYPE

NPTF Threads Leave blank
 BSPF Threads W

OPTIONS: (*More than one option can be chosen. Add in alphabetical order*)

None Leave blank
 0.3-µm-rated element Leave blank
 0.01-µm-rated element E8
 No bowl drain LDC

(1/4-NPT female port instead.)

Use 'BFC' option under **BOWL DRAIN** menu.

No differential pressure gauge NG

PORT SIZE

1-1/4 NPTF 10
 1-1/2 NPTF 12

DIFFERENTIAL PRESSURE GAUGES



Small Slide Gauge
103-151



Large Dual Face Gauge
106-35



Large Dual Face Gauge
with Reed Switch
106-35E (*Normally Open*)
106-35EC (*Normally Closed*)